

F80A active  
F80A e-active

lbs/ft

F80A active

F80A e-active



CRANESWITHOUT COMPROMISE

US

**F80A active**

LIFTING CAPACITY:

up to 60034 lbs.ft

MAX OUTREACH:

up to 40'4" ft with jib

OVERALL DIMENSIONS:

l 2'3" ft, w 7'2" ft, h 6'5" ft

ELECTRONIC/HYDRAULIC EQUIPMENT:

control unit FX500

Hydrocontrol HC/D3M segmented

distributor bank

CHARACTERISTICS:

active version (.0): without linkage

rotation 370° with rack and pinion

FR

**F80A active**

CAPACITÉ DE LEVAGE:

jusqu'à 60034 lbs.ft

BRAS HYDRAULIQUE:

jusqu'à 40'4" ft avec jib

ENCOMBREMENT GRUE:

l 2'3" ft, w 7'2" ft, h 6'5" ft

ÉQUIPEMENT ÉLECTRONIQUE/HYDRAULIQUE:

unité de contrôle FX500

distributeur à éléments

Hydrocontrol HC/D3M

CARACTÉRISTIQUES:

version active (.0): sans bielle

rotation 370° avec crémaillère et pignon

ES

**F80A active**

POTENCIA DE ELEVACIÓN:

hasta 60034 lbs.ft

MÁXIMO ALCANCE HIDRÁULICO:

hasta 40'4" ft con jib

EMBARAZADO GRÚA:

l 2'3" ft, w 7'2" ft, h 6'5" ft

DOTACIÓN ELECTRÓNICA/HIDRÁULICA:

unidad de control FX500

distribuidor hidráulico componible

Hydrocontrol HC/D3M

CARACTERÍSTICAS:

versión active (.0): sin sistema de bielas

rotación 370° con cremallera y piñón

The images are sole purpose of presentation of the product - Les images sont à seule fin de la présentation du produit - Las imágenes son solo propósito de la presentación del producto



US

### F80A e-active

LIFTING CAPACITY:

up to 60034 lbs.ft

MAX OUTREACH:

up to 40'4" ft with jib

OVERALL DIMENSIONS:

l 2'3" ft , w 7'2" ft , h 6'5" ft

ELECTRONIC/HYDRAULIC EQUIPMENT:

control unit FX500

D850 digital distributor bank

RCH/RCS radio remote control unit

CHARACTERISTICS:

active version (.0): without linkage

rotation 370° with rack and pinion

FR

### F80A e-active

CAPACITÉ DE LEVAGE:

jusqu'à 60034 lbs.ft

BRAS HYDRAULIQUE:

jusqu'à 40'4" ft avec jib

ENCOMBREMENT GRUE:

l 2'3" ft , w 7'2" ft , h 6'5" ft

ÉQUIPEMENT ÉLECTRONIQUE/HYDRAULIQUE:

unité de contrôle FX500

distributeur hydraulique digital D850

unité de commande radio RCH/RCS

CARACTÉRISTIQUES:

version active (.0): sans bielle

rotation 370° avec crémaillère et pignon

ES

### F80A e-active

POTENCIA DE ELEVACIÓN:

hasta 60034 lbs.ft

MÁXIMO ALCANCE HIDRÁULICO:

hasta 40'4" ft con jib

EMBARAZADO GRÚA:

l 2'3" ft , w 7'2" ft , h 6'5" ft

DOTACIÓN ELECTRÓNICA/HIDRÁULICA:

unidad de control FX500

distribuidor hidráulico digital D850

unidad de mando radio RCH/RCS

CARACTERÍSTICAS:

versión active (.0): sin sistema de bielas

rotación 370° con cremallera y piñón

The images are sole purpose of presentation of the product - Les images sont à seule fin de la présentation du produit - Las imágenes son solo propósito de la presentación del producto



**F80A active - F80A e-active**  
Gallery







**US RADIO REMOTE CONTROLS**

Radio remote controls of digital generation, to have an absolute operational control of the crane and able to communicate with the operator.

**FR RADIOCOMMANDES**

Radiocommandes de génération digitale pour un contrôle absolu opérationnel de la grue et capables de communiquer avec l'opérateur.

**ES RADIOCOMANDO DIGITAL**

Radiocomando digital para un absoluto control operativo de la grúa y en comunicación con el operario.

## US

### Features

**BASE** - Cast steel base design and the absence of welding allow for long term durability minimizing fatigue and maximizing crane performance.

**BOOM WEAR-PADS** - The cranes feature std. boom wear pads specifically designed and implemented thru the "forced" assembly process providing greater durability and service, allowing for fewer scheduled greasing requirements.

**TANK** - Plastic tank, particularly resistant to shocks and the corrosive action of any external element.

**OUTRIGGER** - STD manual extendable outriggers also in "Extra wide" optional. Optional outriggers include manual extra wide, hydraulic, hydraulic extra wide and hydraulic super extra wide.

**VERSION C** - Crane version with a shorter secondary arm, to allow a greater height of under-hook lifting. Offers the possibility to lift especially bulky and heavy loads vertically, near the column of the crane. Automatic hooking system for the positioning of the extension booms in transport position when crane is folded behind cab.

### Optional

**WORK LIGHT** - Powerful and versatile light that can be directed as required: helps you to work safely, even in conditions of poor natural light. Can be activated by means of the radio remote control pushbuttons or by the user panel.

**JIB** - Additional hydraulic articulation that allows you to increase the reach of the crane and, once the required height has been reached, to move the load horizontally in relation to the ground (without jeopardizing the correct resting configuration of the crane).

**SEAT** - Ergonomic, protected position to allow the operator greater control when carrying out specific movement and lifting operations. There are many possibilities of adjustments to find out the most comfortable working and control position and heated top seat as option.

**SUPPLEMENTARY FUNCTIONS** - Supplementary functions for the use of hydraulic accessories on the crane and the jib, protected by an exclusive Fassi system consisting of metal trays paired with highly resistant nylon guide-chains. High quality hoses resistant to the external wear

**WINCH** - Cable-operated lifting device equipped with an exclusive, patented mechanical, torque and end stop limiter system which avoids the risks resulting from direct and indirect overload applied to the winch itself. Anti-twist cable and cable guide pulley to make easy the aligned winding of the cable on the winch drum.

## FR

### Caractéristiques

**EMBASE** - Embase et partie inférieure de la colonne en fusion de fonte pour avoir une répartition optimum des sollicitations et une résistance plus importante. L'absence de soudures donne à la grue une longévité exceptionnelle.

**PATINS DE GUIDAGE** - Patins de guidage sur les bras d'extension, à montage "forcé" afin de réduire les jeux verticaux et latéraux prolongeant ainsi la durée de vie de l'ensemble. Patins en matériel spécial avec un degré de glissement élevé et demande réduite d'engrissage.

**RÉSERVOIR** - Réservoir en matière plastique très résistant aux chocs et à l'action corrosive de tout élément extérieur.

**STABILISATEURS** - Stabilisateurs pivotants à extension manuel, disponible aussi en version "Extra large", "Super Extra large" et "Iper Extra Large".

**VERSION C** - Version de la grue avec un bras secondaire plus court, de manière à obtenir une hauteur sous crochet plus importante. Elle donne la possibilité de soulever verticalement, au plus près de la colonne de la grue, des charges très encombrantes et lourdes. Système d'accrochage automatique pour le positionnement des bras d'extension en position de transport avec grue repliée derrière cabine.

### En option

**PHARE DE TRAVAIL** - Phare directionnel variable, puissant et adaptable, qui permet de travailler en toute sécurité même avec une mauvaise visibilité. Peut être activé également avec les boutons de la radiocommande ou du panneau utilisateur.

**JIB** - Articulation hydraulique supplémentaire permettant d'augmenter l'extension de la grue et, une fois la hauteur désirée atteinte, de déplacer la charge horizontalement par rapport au sol (sans intervenir sur la configuration initiale de la grue au repos).

**SIÈGE** - Poste ergonomique et protégé qui permet à l'opérateur un contrôle optimal lors d'opérations de déplacement et de levage spécifiques. Position de travail et des commandes réglable et option siège réchauffé.

**TUYAUTERIES SUPPLÉMENTAIRES** - Tuyauteries supplémentaires pour l'utilisation d'accessoires hydrauliques, sur grues et sur rallonges hydrauliques, protégées par un système exclusif Fassi se composant de supports en métal couplés à des chaînes de guidage en nylon à haute résistance. Tuyauteries flexibles de grande qualité résistantes à l'ozone.

**TREUIL** - Dispositif de levage par câble équipé du système exclusif breveté de limiteur de couple et de fin de course mécanique, évitant les risques de toute surcharge directe ou indirecte infligée au treuil. Câble anti-giratoire et poulie de guidage pour enroulement aligné et facilité du câble sur le tambour.

## ES

### Características

**BASE** - Base y parte inferior de la columna de fundición de hierro colado para una distribución ideal de los esfuerzos de carga y resistencia superior. La ausencia de soldaduras confiere a la grúa características excepcionales de resistencia a la fatiga.

**PATINES DE GUÍA** - Patines de guía de los brazos extensibles, con montaje "forzado" para reducir las holguras verticales y laterales, garantizando una vida útil más larga. Patines especiales con elevado grado de deslizamiento y baja necesidad de engrase.

**DEPÓSITO** - Depósito de material plástico especialmente resistente a los golpes y a la acción corrosiva de cualquier elemento externo.

**ESTABILIZADORES** - Estabilizadores rotantes a extensión manual también en versión "Extra extensible", "Super Extra extensible" y "Iper Extra extensible".

**VERSIÓN C** - Versión de grúa con un brazo secundario más corto, con el fin de permitir una mayor altura de elevación debajo del gancho. Ofrece la posibilidad de levantar en vertical, cerca de la columna de la grúa, cargas especialmente grandes y pesadas. Sistema de enganche automático para el posicionamiento de los brazos extensibles en posición de transporte con la grúa plegada detrás de la cabina.

### Opcional

**FARO PARA TRABAJO** - Poderoso y versátil faro de dirección variable, ayuda a trabajar en seguridad, también en condiciones de iluminación escasa del ambiente. Se puede activar también mediante el cuadro de pulsadores del radiocomando o del panel de usuario.

**JIB** - Articulación hidráulica adicional que permite aumentar el alcance de la grúa y, después de haberse alcanzado la altura deseada, desplazar la carga horizontalmente con respecto al terreno (sin perjudicar la prevista configuración en reposo de la grúa).

**ASIENTO** - Puesto ergonómico protegido para permitir al operario un mayor control en caso de operaciones específicas de manipulación y elevación. Posición de trabajo y de los mandos regulables y opción de asiento calefactado.

**TUBERÍAS ADICIONALES** - Tuberías adicionales para el uso de accesorios hidráulicos, en grúas y en extensiones hidráulicas, protegidas por un sistema Fassi exclusivo constituido por canaletas metálicas combinadas con cadenas de guía de nylon de alta resistencia. Tubos flexibles de alta calidad y resistentes a la acción del ozono.

**CABRESTANTE** - Dispositivo de elevación por cable equipado con un exclusivo sistema patentado de doble limitador final de carrera mecánico, que evita los riesgos que derivan de las sobrecargas directas e indirectas aplicadas sobre el propio cabrestante. Cable anti giro y polea guiada para rebobinado alineado al tambor.



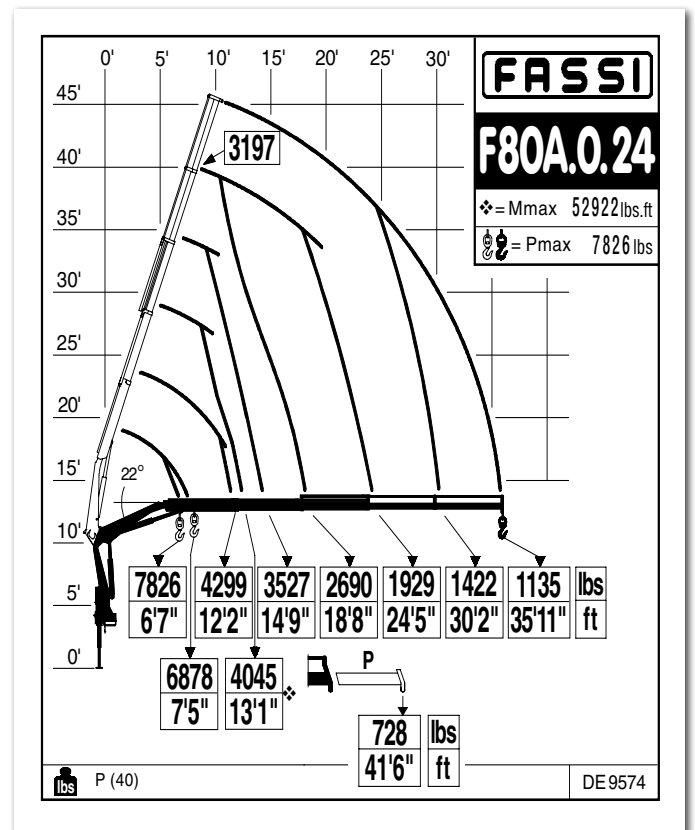
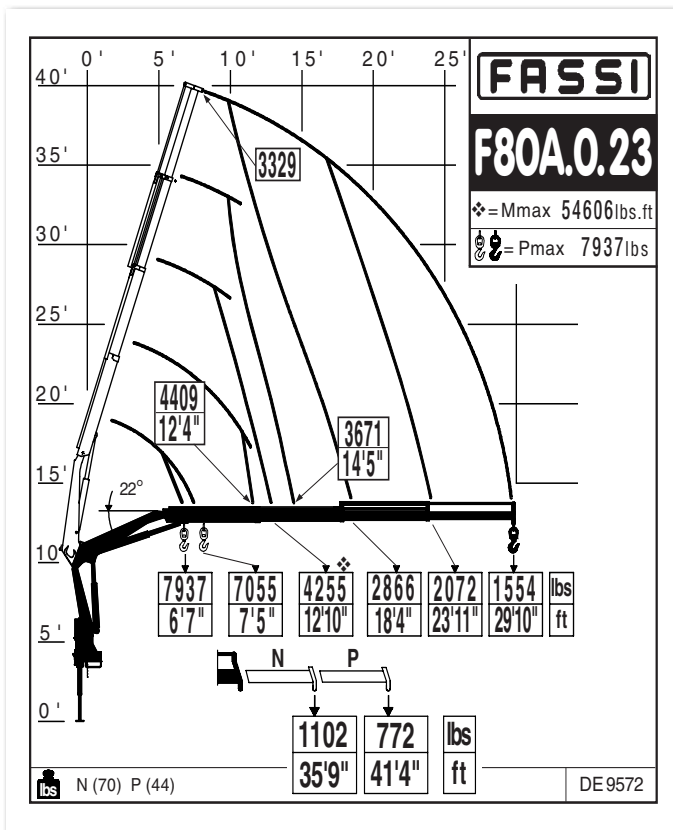
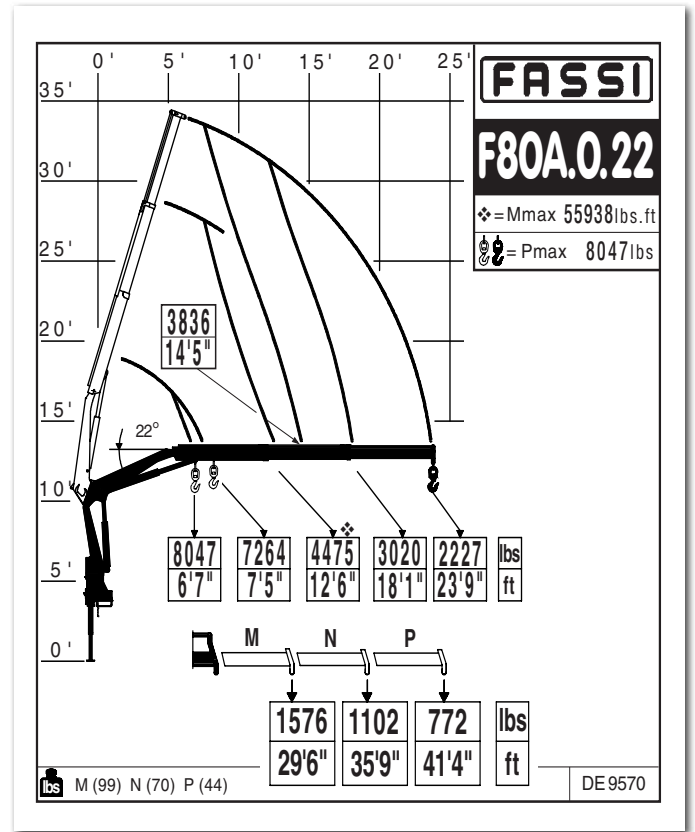
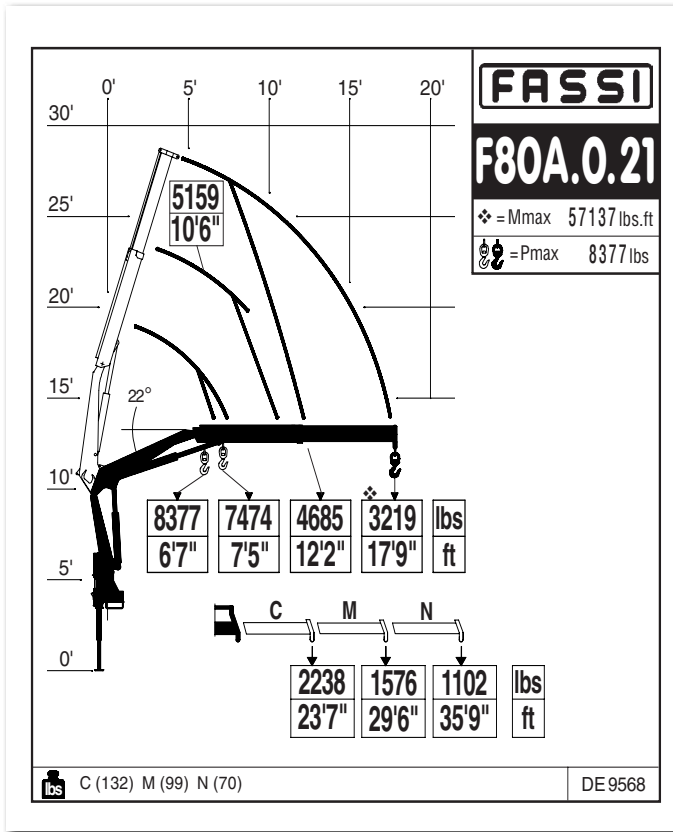

- US Dynamic load diagrams calculated, tested and certified to lift the loads at the declared reaches
- FR Diagrammes de charge dynamiques calculés, testés et certifiés pour soulever les charges aux extensions déclarées
- ES Diagramas de carga dinámicos, calculados, probados y certificados para a elevación de la cargas a los alcances declarados



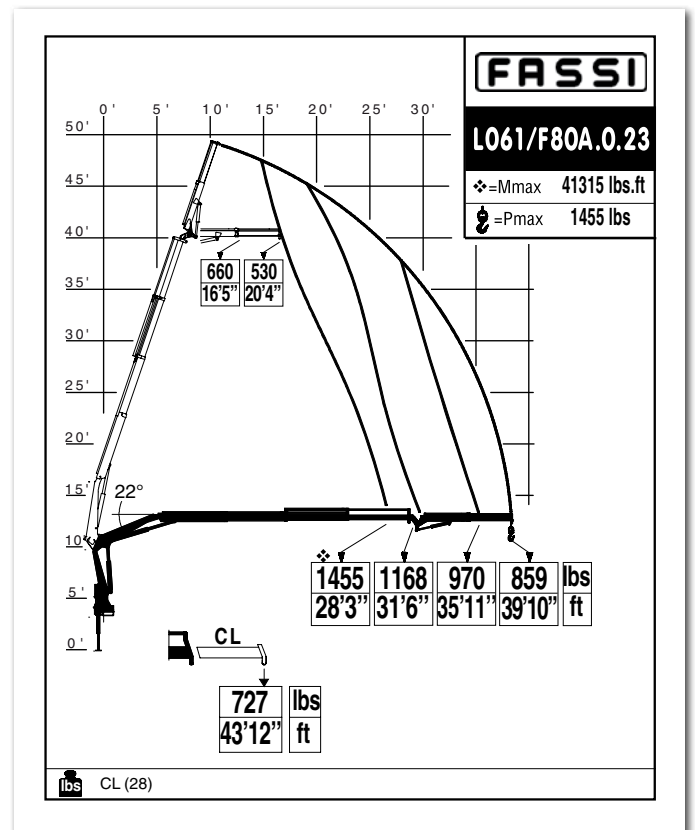
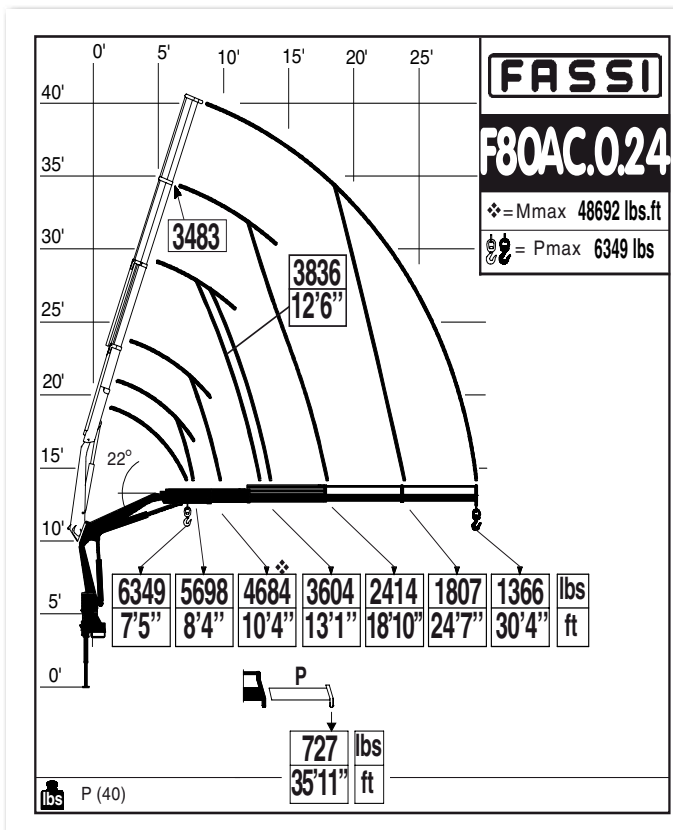
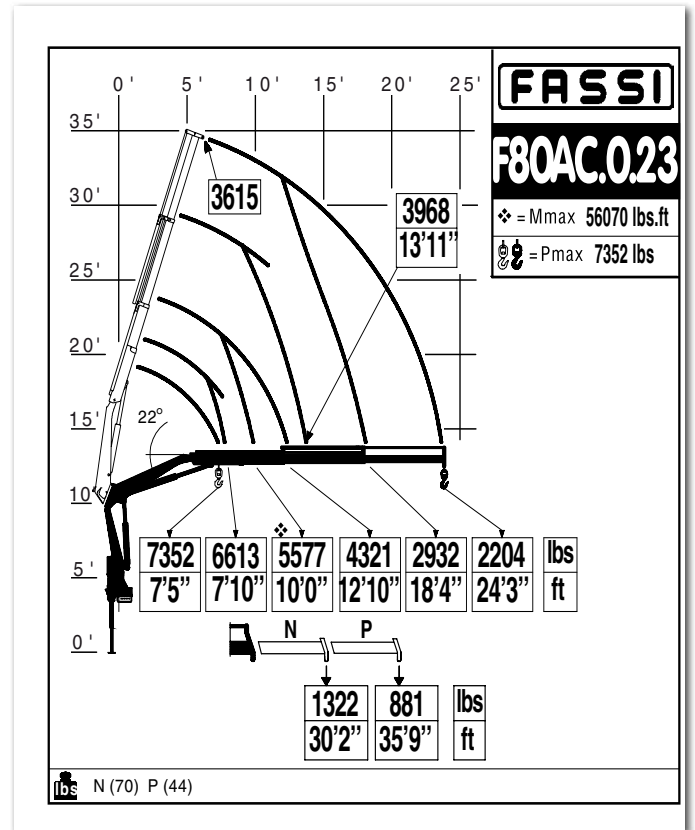
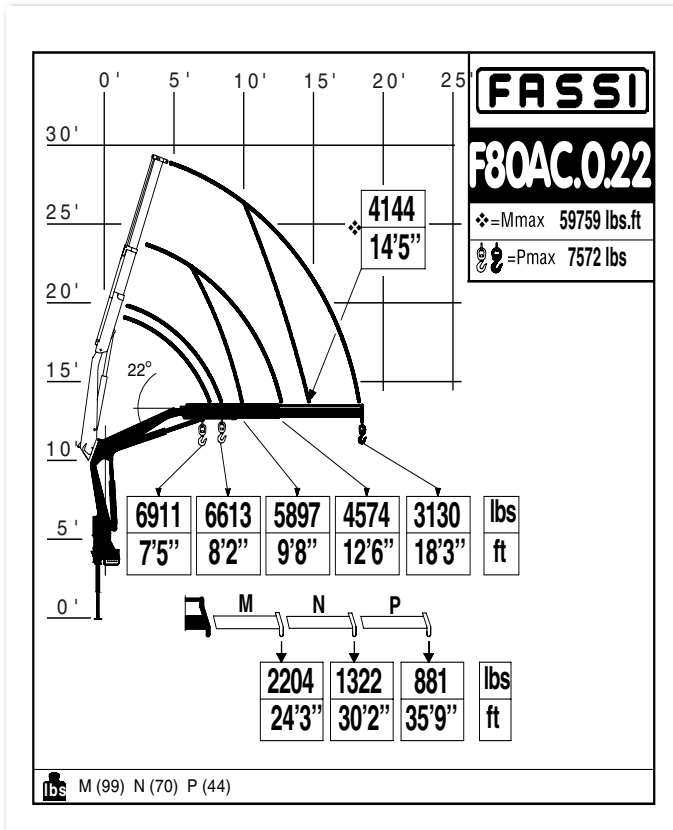



















































**CERTIFIED**  
**DYNAMIC**  
**PERFORMANCE**

- US Dynamic load diagrams calculated, tested and certified to lift the loads at the declared reaches
- FR Diagrammes de charge dynamiques calculés, testés et certifiés pour soulever les charges aux extensions déclarées
- ES Diagramas de carga dinámicos, calculados, probados y certificados para a elevación de la cargas a los alcances declarados

# F80A active - F80A e-active

## Technical data

lbs/ft												
	lbs.ft	m	m	°	lbs.ft	psi	gpm	gal	lbs	ft	ft	ft
F80A.0.21	57137	18'4"	5'6"	370	8632	4350	5	24	2116	7'3"	2'3"	6'5"
F80A.0.22	55938	24'3"	11'3"	370	8632	4350	5	24	2259	7'3"	2'4"	6'5"
F80A.0.23	54606	30'6"	17'0"	370	8632	4350	5	24	2447	7'3"	2'4"	6'5"
F80A.0.24	52922	36'5"	22'9"	370	8632	4350	5	24	2579	7'3"	2'4"	6'5"
F80AC.0.22	59759	18'8"	8'6"	370	8632	3920	5	24	2182	7'3"	2'4"	6'5"
F80AC.0.23	56070	24'9"	14'5"	370	8632	3920	5	24	2369	7'3"	2'4"	6'5"
F80AC.0.24	52922	30'10"	20'0"	370	8632	3920	5	24	2513	7'3"	2'4"	6'5"
F80A.0.23/L061	56070	40'4"	20'11"	370	8632	4350	5	24	2744	7'3"	2'10"	6'5"

												
	Lifting capacity	Standard reach	Hydraulic extension	Rotation	Rotation torque	Working pressure	Pump capacity	Oil tank capacity	Crane weight	Crane width	Installation width	Crane height
												
	Capacité de levage	Bras standard	Extension hydraulique	Rotation	Couple de rotation	Pression d'utilisation	Débit de la pompe	Capacité du réservoir d'huile	Poids de la grue	Largeur de la grue	Largeur de montage	Hauteur de la grue
												
	Capacidad de elevación	Brazo standard	Extensión hidráulica	Ángulo de rotación	Potencia de rotación	Presión de trabajo	Capacidad de la bomba	Capacidad depósito aceite	Peso de la grúa	Anchura de la grúa	Anchura de montaje	Altura de la grúa

**F80A active - F80A e-active**

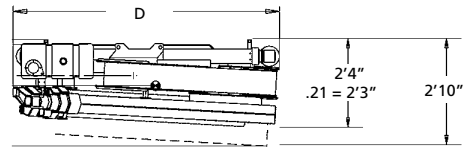
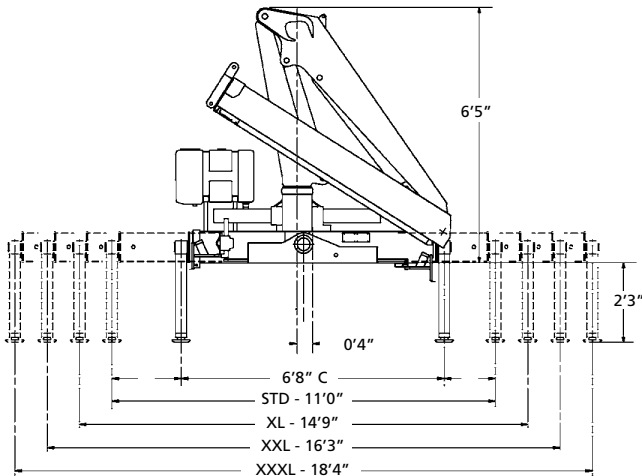

	STD	XL	XXL	XXXL
<b>A</b>	2'6"	3'10"	4'5"	5'10"
<b>B</b>	1'9"	3'10"	4'5"	5'2"
<b>C</b>	6'8"	6'11"	7'3"	7'3"
<b>D</b>	7'3"	7'6"	7'10"	7'10"

**L SERIE**

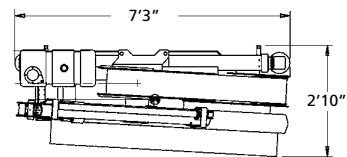
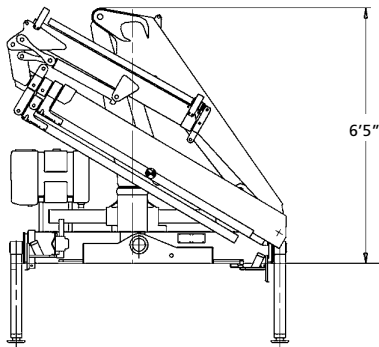

<b>L061</b>	275 lbs
<b>CL</b>	28 lbs

**F80A active - F80A e-active**

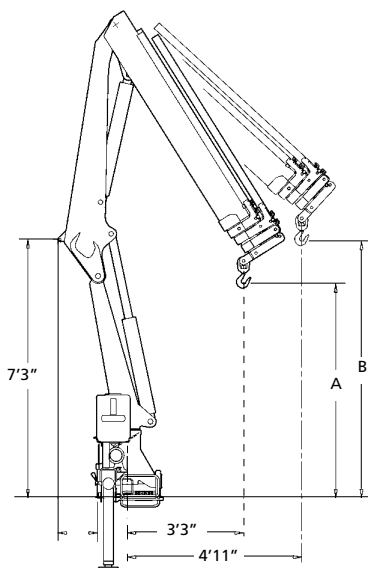

	A	B
<b>F80A.0.21</b>	6'11"	8'5"
<b>F80A.0.22</b>	6'8"	8'0"
<b>F80A.0.23</b>	6'4"	7'7"
<b>F80A.0.24</b>	6'0"	7'2"

**F80AC active - F80AC e-active**

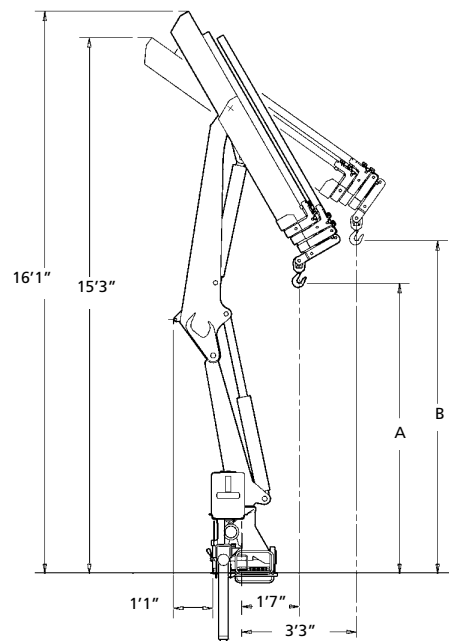

	A	B
<b>F80AC.0.22</b>	8'11"	10'5"
<b>F80AC.0.23</b>	8'7"	10'0"
<b>F80AC.0.24</b>	8'3"	9'6"



## US

### ELECTRONIC DOCUMENTATION

All documentation related to the "Techno chips" and the crane is available in electronic format. Require all information you may need directly to your Fassi dealer or download them from the internet site: [www.fassi.com](http://www.fassi.com).

## FR

### DOCUMENTATION ELECTRONIQUE

Toutes les informations relatives aux "Techno chips" et aux grues sont disponibles sous format électronique. Elles peuvent être demandées aux concessionnaires Fassi ou téléchargées sur le site [www.fassi.com](http://www.fassi.com).

## ES

### DOCUMENTACION ELECTRÓNICA

Toda la información relativa a los "techno chips" y a las grúas está disponible en formato electrónico. Se puede solicitar directamente a los concesionarios Fassi, o bien descargarse on line desde la web [www.fassi.com](http://www.fassi.com).

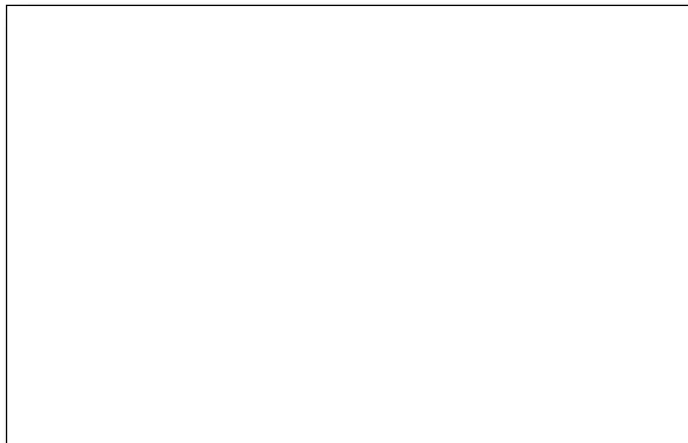

**FASSI**

[www.fassi.com](http://www.fassi.com)

FASSI GRU S.p.A.  
Via Roma, 110  
24021 Albino (Bergamo) ITALY  
Tel- +39 035 776400  
Fax +39 035 755020  
<http://www.fassi.com>  
E-mail: [fassi@fassi.com](mailto:fassi@fassi.com)

COMPANY  
WITH QUALITY MANAGEMENT  
SYSTEM CERTIFIED BY DNV  
=ISO 9001: 2008=